

# Geosyntec

## Oil and Gas Sector Services





Founded in 1983, Geosyntec is a leading consulting and engineering family of companies with over 1,200 practitioners that operates globally, with focus on North America, Europe, Asia, and Australia.

Our high-value services, first-to-field deployment of emerging technologies, and innovative solutions are recognised by many clients as a key differentiator and reason for using Geosyntec, whether from the private or public sector.

Our private sector clients come from a variety of industries, including oil and gas, chemical, aerospace, pharmaceutical, diversified manufacturing, advanced technology, power and utility, and environmental management. They also include regional and national developers, large commercial property owners, and the legal-financial sector. Our public sector clients comprise departments and agencies of national, regional, state, provincial, and municipal governments.

For over 30 years we have grown based on the application of sustainability principles to projects involving environmental contamination studies and remediation; water and natural resources assessment and restoration; compliance management of air emissions, wastewater discharges, and waste disposal; and engineering and design of environmental, water resources, and civil infrastructures. Geosyntec holds a unique position in the consulting and engineering marketplace through our ability to combine innovative technology and practice leadership with exceptional client service and project delivery excellence. Our services and solutions are highly valued and sought after by our clients, with most of our assignments coming via repeat client business.



engineers • scientists • innovators

MMI Engineering (MMI) is a division of Geosyntec and provides specialised engineering, safety, security and risk management services to Geosyntec's clients on a global basis. We undertake projects on facilities to:

- Minimise risks from natural, accidental, and malicious events - such as fires, explosions, earthquakes, impacts, and tsunamis;
- Manage the integrity of facilities to ensure their safe, long-term performance; and
- Optimise process improvements - reducing risk to business performance.

MMI helps clients manage risks on their facilities that could affect life, the environment, asset performance, or business interruption by providing:

- Safety and risk management studies to identify risks and their likelihood;
- Detailed computational modelling studies to predict behavior; and
- Analysis and engineering to mitigate hazards or optimise processes, delivering designs and advice that can be implemented.

MMI advises clients in the areas of defence and security, nuclear, oil and gas, chemical and petrochemical, conventional power, clean energy, water utilities, and the legal and financial sectors. Our people have diverse backgrounds in research, design, consulting, construction, and operations. Skill sets cover the mechanical, structural, civil, chemical, process engineering, physics, and chemistry disciplines - often to PhD level. Like our colleagues at Geosyntec, MMI has internationally recognised practitioners who have established the state-of-the-art in most of our practice areas.

## MMI Engineering in the Oil & Gas Industry



We provide specialized technical consulting support on a global basis to Operators, EPCs, Consultants and Regulators - assisting in the management of technical, commercial and safety risks.

### Our services include:

- Safety and Risk;
- Process Safety;
- Flow Assurance;
- Production Efficiency;
- Structures and Foundations;
- Major Accident Hazards;
- Fire and Blast Engineering;
- Riser Design;
- Plant Integrity;
- Security;
- Research and Development.

We employ engineering and scientific personnel from research, design, construction, operations and project management backgrounds - many with experience in challenging environments such as highly seismic, high hazard, deepwater, subsea High Pressure / High Temperature (HPHT) fields, cryogenic applications and arctic regions.

Even with challenging project and operational timescales, MMI brings innovation to projects and operations that depend on our core practice areas of risk management, design and engineering, analysis and simulation, fluid mechanics and geotechnical engineering.

# Risk Management

MMI understands all aspects of the risk management process, from the very earliest consideration and the design, build and maintenance of risk reduction measures.

We know that risk assessment is only the important first step to true risk management, which requires identification of major accidents. Between us, we have hundreds of years of experience 'across the Bowtie'.

- HAZID;
- HAZOP;
- CHAZOP;
- Human Factors;
- Structural Integrity;
- Metocean studies;
- Shipping Risks;
- Helicopter Risks;
- Incident Reports.

- Knot' of BowTie
- FMEA
- BowTie
- PFEER / SCE / Pro
- Safety Mana
- ALARP Demonstratio

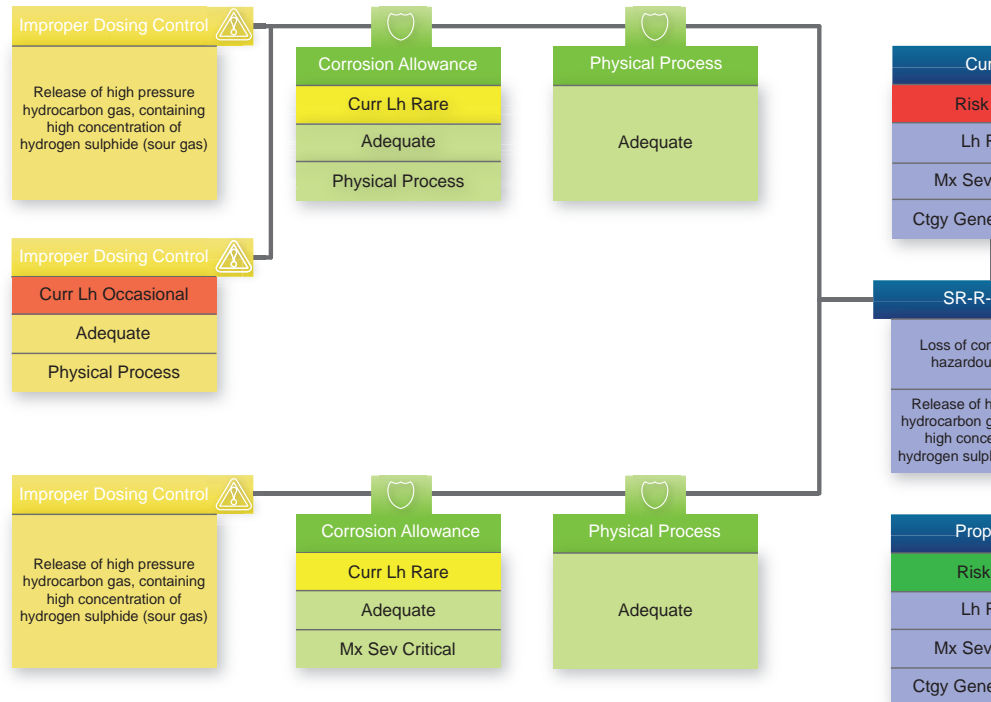

- Risk Based Inspection;
- Risk Centred Maintenance;
- Human Factors Studies;
- Structural Integrity;
- Process Modelling;
- Erosion Modelling;
- Dropped Object Studies;
- Ship Impact Studies.

Integration of inherently safe design through hazard identification, assessment of consequences

Implementation and full life cycle management of measures to reduce the likelihood and consequences

- Risk Assessments;
- QRA;
- HAZOP / FMECA;
- Hazard and Operability Analysis;
- Process Safety Compliance
- Audits;
- Management Systems;
- Options / Cost Benefit Analysis.

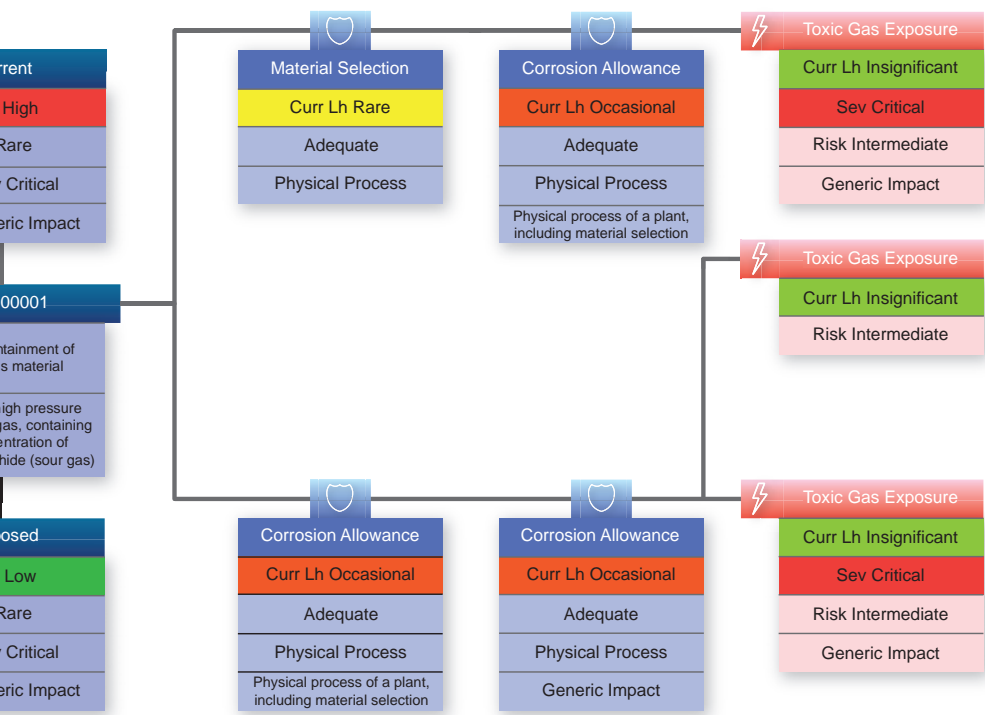

- Structural Fire Response;
- Blast Response;
- Emergency Response;
- Evacuation Studies;
- Escalation Studies.

- Passive Fire Protection Systems;
- Fire and Explosion Risk Assessment;
- Blast Wall Design;
- Gas and smoke Dispersion;
- Fire and Gas Detection Systems;
- Process Safety Training for Responders.

# Understanding Hazards & Risks

MMI fully services the client's risk identification and reduction needs, providing more than just a single discipline service.

## Health, safety, environment & security services include:

- HAZID and HAZOP Facilitation;
- Safety Case Preparation and Thorough Reviews (SCR, COMAH, Seveso II, etc.);
- Implementing Process Safety (PSM, SEMS, etc.);
- Quantitative Risk Assessment (QRA);
- Safety Management System (SMS) Development and Auditing;
- Safety Critical Element (SCE) Identification;
- Emergency Systems Survivability Analysis (ESSA);
- Escape, Evacuation and Rescue Analysis (EERA);
- Failure Modes Effect and Causality Analysis (FMECA);
- Demonstrating ALARP;
- Due Diligence;
- Security Vulnerability Assessments;
- Environmental Assessments;
- Functional Safety Assessments and Verification (SIL);
- Reliability Modelling Assessments.

## Risk management tools & techniques used include:

- BowTie;
- ENVID;
- Fault Tree+;
- HAZCON;
- HAZDEM;
- HAZOP;
- HAZID;
- HIRA;
- LOPA;
- MMIQRA;
- ATEX;
- RAM.



## Quantification of the Hazards

Modelling using industry validated tools and methodologies allows hazards to be clearly quantified so their impact can be determined.

### Hazard modelling includes:

- Gas dispersion and explosion;
- Jet and Hydrocarbon Fires, Pool Fires and BLEVEs;
- Design Accident Load (DAL) Development;
- Smoke and Toxicity Dispersion and TR Ingress;
- Seismic Hazard;
- LNG, CNG, CO<sub>2</sub>, NO<sub>x</sub>, H<sub>2</sub> & H<sub>2</sub>S Release;
- Flare Radiation;
- Subsea Release Modelling.

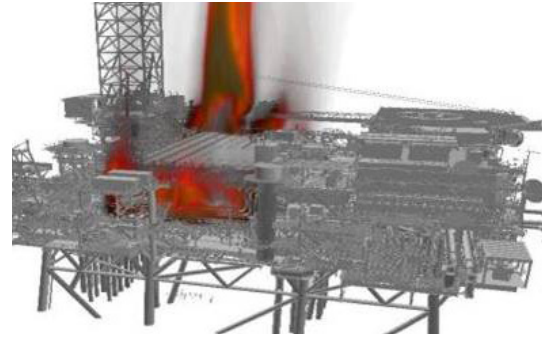

### Modelling tools used include:

- ANSYS CFX;
- FLACS;
- Cirrus & FRED;
- FDS;
- FlareSim;
- Kameleon KFX;
- OPENFire;
- OpenFoam;
- PHAST;
- VessFire.

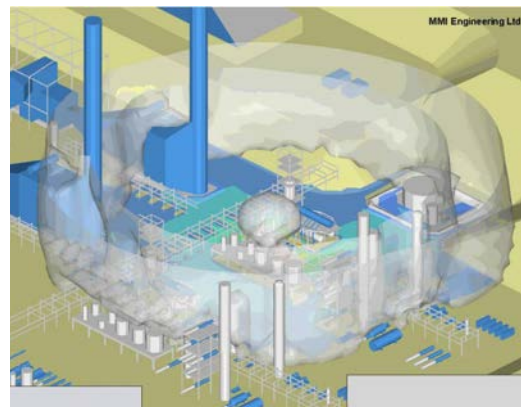
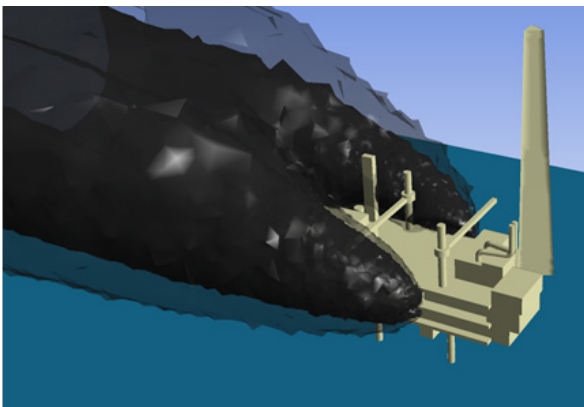
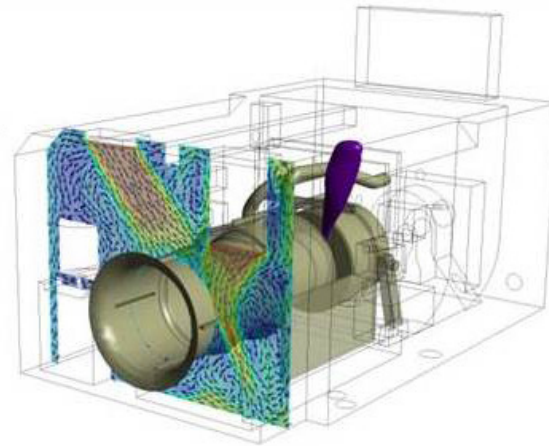

# Hazard Response Analysis

Analyzing structures, plant, pipelines and equipment that are subjected to major hazards requires specialist knowledge and tools to ensure that the non-linear, dynamic response is predicted correctly.

## Hazard response services include:

- Fire Load Response Analysis;
- Blast Response Analysis;
- Seismic Response Analysis;
- Extreme Environmental Load Pushover Analysis;
- Engineering Criticality Analysis;
- Fitness for Service Evaluation;
- Ship Impact and Dropped Object Assessment;
- Flow Assurance and Erosion Modelling;
- Fire and Gas Detector Layouts;
- Pipeline and Network Modelling.

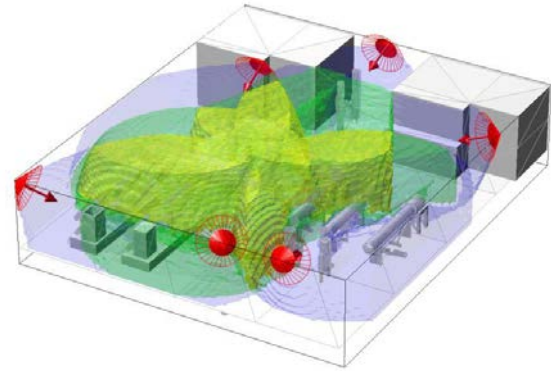

Fire Detector Optimization

## Analysis tools used include:

- ABAQUS;
- ANSYS;
- LS-DYNA;
- SACS;
- USFOS;
- Staad;
- CFX;
- Fluent;
- FlowMaster;
- Pipenet.

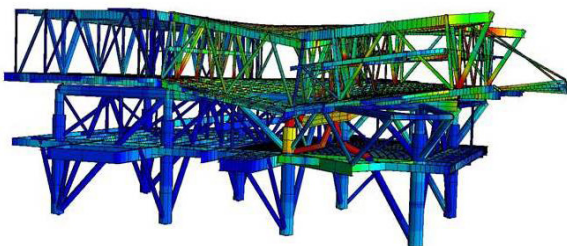
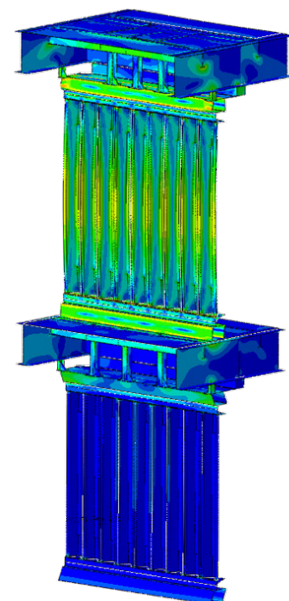
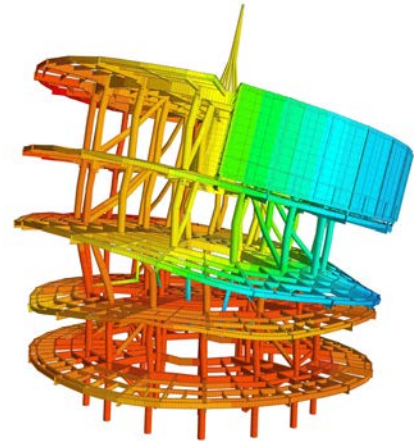



# Hazard Mitigation

With the loads and response captured, MMI's engineers can design and detail specialist, cost effective mitigation measures that are fit for purpose and manage the risks - true risk management.

## Blast Resistant Design

- Steel and Composite Blast Walls;
- Control Room Design and Retrofit;
- Portable Building Design;
- Blast Relief Panels;
- Equipment and Pipe Supports.

## Passive Fire Protection (PFP) Design

- Structural Coating Optimization;
- Fire Barriers;
- Process Vessels;
- Riser, Valve and Actuator Protection;
- Penetration Sealing.

## Cryogenic Spill Protection (CSP) Design

- Coating Specification and Design;
- Insulation System Design.

## Active Fire Protection System Design

- Full Firewater System Design;
- Hydraulic Calculations for Ringmains.

## Seismic Assessment and Design

- Retrofit and Strengthening;
- Seismic Isolation Techniques;
- Structures, Plant and Control Systems.

## Impact Protection

- Subsea Dropped Object Protection;
- Topside Protection Systems;
- Ship Impact and Berthing Fender Systems;
- Security Vehicle Barrier Systems.



Blast Wall with Energy Absorption

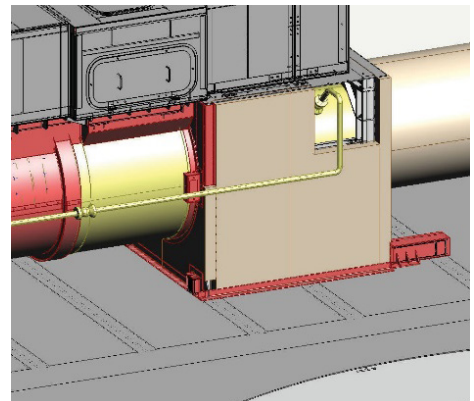

ESD Valve Fire and Blast Protection



Firewall PFP Design

# Passive Fire Protection (PFP)

MMI are world leaders in the area of PFP, be it R&D, the assessment, remediation and long term management of aging systems, or the full design, assessment and auditing for new projects.

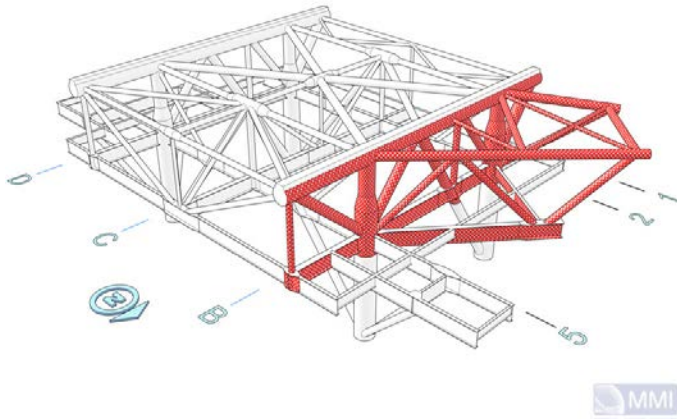

## PFP Consulting

- Research and Development;
- Code, Standard and Guidance Development;
- Fire and Blast Testing, Design and Assessment;
- Product Certification Assistance;
- Materials and Systems Specification;
- Training and Competency.

## PFP Scheme Development

- Fire Risk Assessment;
- Design Accident Load Development;
- Jet and Pool Fire Modelling;
- Fire Load Response Analysis;
- PFP Scheme Design and Optimization;
- Independent Inspection and Auditing.

## PFP Inspection & Integrity Management

- Inspection and Maintenance Strategy Development;
- Detailed Inspection and Condition Assessment;
- Assessment of Material Degradation;
- Repair Strategy;
- Inspection and Audit of Repairs;
- Life Extension Management.



## Integrity Management

Our expertise in asset integrity and asset reliability assessments makes us the ideal choice for asset integrity management for major operators.

MMI offers a range of services including fitness-for-service, remnant life assessments, engineering criticality / substantiation services and asset integrity management of structures as well as pressure systems.

Asset integrity management services include:

- Asset Integrity Management System Development;
- Structural Integrity Assurance;
- Business Continuity Evaluation;
- Sustainability Evaluation;
- Engineering Criticality Assessment;
- Fitness for Service Evaluation;
- Remnant Life / Life Extension;
- Accident Investigation / Root Cause Assessment.



# Hazards Awareness & Communication

At MMI, we pride ourselves on making complex engineering analysis accessible to a wide range of audiences.

## Design services undertaken by MMI include:

- Multi-Media Development;
- Training;
- Simulation and Visualization;
- Accident / Incident Investigation.

MMI Engineering has developed and patented a tool that allows for the real-time simulation of major hazard accidents and the injuries to individuals exposed to them. The tool was developed in the Unity game engine, which means it can be deployed across a range of operating systems including PC, Mac, Web, iOS, Android, and the Virtual Reality platform Oculus Rift. QUARTS allows the user to navigate their own working environment in an immersive, virtual environment and to experience exposure to major developing incidents.

QUARTS was originally designed for situational awareness training for fire and explosion awareness, but could be adapted for many different purposes, such as:

- Induction Training;
- Site Orientation;
- Fire Fighting;
- Emergency Response Training;
- First Responder Training;
- Evacuation Analysis.

We also see the potential of Oculus in providing:

- Pre-Visit Orientations;
- Inductions;
- Coxswain training;
- Signage;
- Optimization;
- 3D User Interfaces.



QUARTS Experienced Through  
Oculus Rift at Hazards 24

# Due Diligence Services

Together with our parent company, Geosyntec, we are able to help our clients to understand and place a value on most aspects of technical due diligence.

We have extensive experience in helping clients to understand, quantify, visualize and communicate the technical environmental and safety risks posed by natural and man-made hazards to the oil and gas, water and wastewater, energy, government, industrial, and commercial markets.

We use a range of state-of-the-art engineering, science, and technology in combination with the practical design, construction, and project management experience of our staff. Depending on the objectives of the due diligence we are able to tailor our offering to address specific needs, ranging from a simple qualitative check-list based study, through to detailed analytical studies to provide quantitative evaluation of the risks.

We offer a full range of due diligence services depending on the level of detail required and the perceived risk. In general, a three stage approach is adopted:

## Phase I – Screening Study

- Data Room Inspection (Virtual / Physical);
- Questionnaire and Interviews;
- Site Visit;
- Audit.

## Phase II – Detailed Investigation

- Field Investigations of High Potential Issues Identified in Phase I;
- Detailed Technical Study of High Potential Issues Identified in Phase I.

## Phase III - Remediation

- Development of Rectification and Remediation Solutions, Based on the Findings of the Phase II Studies.

Our consultants understand how science and engineering should be incorporated into risk management strategies for true, pragmatic and cost effective risk reduction. We specialize in the appropriate application of innovative, high quality science and engineering to the evaluation and mitigation of risks posed by major hazards and threats.



# Plant Integrity Management

Our expertise in integrity and reliability assessments makes us the ideal choice for integrity management for major operators.

We offer a range of services, including fitness-for-service, remnant life assessments, engineering criticality / substantiation services and asset integrity management of structures, static equipment, and rotating equipment.

Integrity services include:

## Mechanical

- Fracture Mechanics;
- Thermal Stress Analysis;
- Material Selection;
- Vibration Induced Failure (AVIFF);
- Flow-Induced Vibration (FIV);
- Rotating Equipment Loads.

## Structural

- Structural Reliability Analysis;
- Wave and Green Sea Loads;
- Asset Life Extension;
- Accident and Failure Investigation;
- Fire-Damaged Integrity;
- Fixed and Floating Fatigue Life.

We're familiar with all the main assessment codes, including API579 Level 3, PD5500, R6, AVIFF, ASME, and DNV Standards.

Tools include:

- ABAQUS;
- ANSYS;
- X-FEM;
- USFOS;
- SESAM.

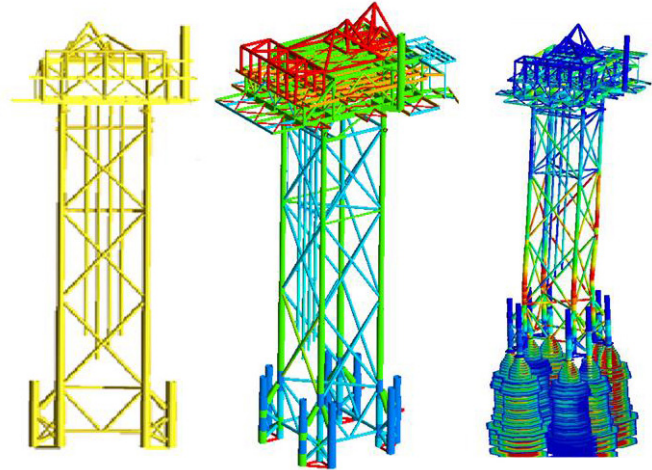

Limit State Design Services for Offshore Structures

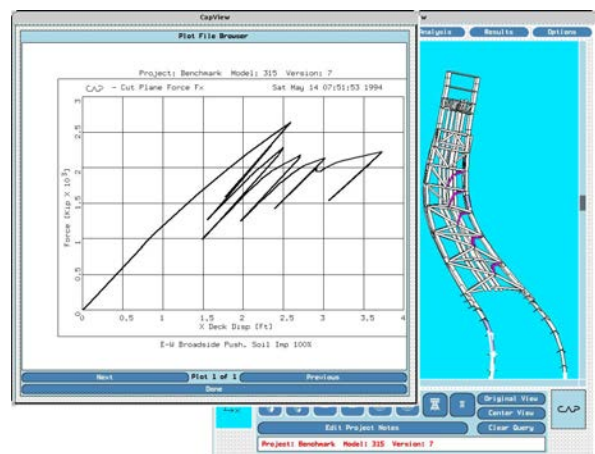

Structural Risk Assessment

# Process & Flow Assurance

Some of the most difficult problems facing operators are assuring that production continues despite changing conditions. We use our fluid dynamic expertise to solve these problems.



We don't rely on a single software tool, but on a clear understanding of the physics of fluid mechanics. In particular, we are experts at complex gas dynamics problems, multi-phase flows, and non-Newtonian rheology. Services include:

## Process

- Component Performance;
- Separation Optimization;
- Thermal Mixing;
- Three-Phase Separation;
- Flare System Performance;
- J-T Cooling.

## Flow Assurance

- Subsea Cool-Down Studies;
- Hydrate Formation Prediction;
- Erosion Modelling;
- Valve Dynamics;
- Inhibitor Injection Performance;
- Unstable Flows.

Tools we use include:

- ANSYS;
- CFX/Fluent;
- Flowmaster;
- HYSYS;
- Ledaflow;
- Pipenet.

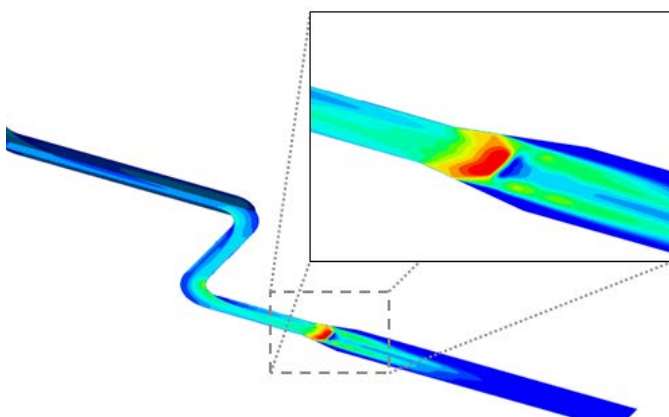
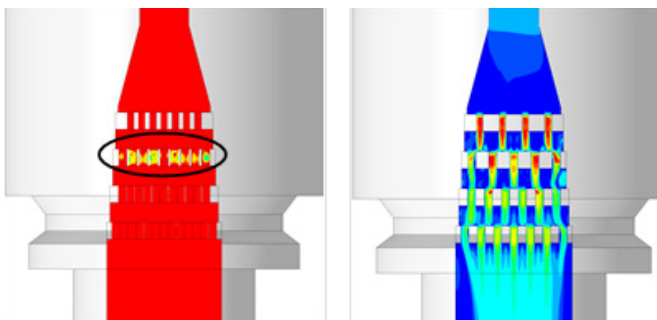

## Production Efficiency

Operators must efficiently manage their operations in order to maximize returns. We help our clients manage operational and maintenance practices to get the best from their assets.

We have a vibrant mix of experienced operators and mathematical modelers to help our clients identify both quick wins and long-term investments that will add value to their business. Services include:

- Production Profile Modelling to Identify Problems in Your Asset - and Connected Assets, Too;
- Root Case Analysis to Establish why Equipment Really Fails;
- Spares Studies to Optimise Your Spares Holding and Minimise Production Risk;
- Engineering Financial Analysis to Support Investment Decisions Beyond Net Present Value (NPV);
- Reliability Analyses That Identify Critical Items;
- Human Factors Studies to Reduce the Cause of Human Error.

The techniques we use include FMECA, RCM, RCA, FTA, and detailed studies of the physics of failure using CFD, FEA and electromagnetic analysis software. These mathematical techniques are deployed alongside an experienced team of operational practitioners, and together give our customers insight and clarity.





## Our Oil & Gas Clients



We offer highly qualified and effective support to clients in the upstream, midstream, refining, petrochemical, LNG, storage and transportation sectors.

- Aker Solutions;
- AMEC Foster Wheeler;
- Anadarko;
- Apache;
- Bechtel;
- Bilfinger Salamis;
- Bluewater;
- BP;
- BG Group;
- Britannia;
- BSEE;
- BW Offshore;
- CB&I;
- Centrica ;
- Chevron ;
- Chevron Phillips;
- CNOOC Nexen;
- CNR;
- ConocoPhillips;
- Costain;
- DNO;
- ENI;
- EnQuest;
- ExxonMobil;
- Fairfield Energy;
- Fluor;
- GustoMSC;
- Hess;
- HSE;
- Hunt Oil;
- Husky Energy;
- Inpex;
- JGC;
- KBR;
- Maersk Oil;
- Marathon Oil;
- MODEC;
- Murphy Oil;
- Mustang;
- Petrofac;
- Petronas
- **Plains;**
- **Premier Oil;**
- **PTT;**
- **Sabic;**
- **Saipem;**
- **SBM;**
- **Shell;**
- **Siemens;**
- **Statoil;**
- **Talisman Sinopec;**
- **TAQA;**
- **Technip;**
- **Total;**
- **TPC;**
- **Woodside;**
- **WorleyParsons.**

## Our People

Our staff are recruited from the industry to support the industry. At least 30% of MMI consultants are PhD qualified, and many retain working links with academic institutions.

This ensures continuous innovation and the development of new approaches.

- MMI employs over 100 consultants worldwide, most of whom are qualified to MSc or PhD level;
- Our oil & gas experience covers design, construction and operations;
- We provide specialist design, analysis, safety report authoring and independent review services for the nuclear industry;
- We are a recognised leader in risk management in wind energy, marine energy, carbon capture and sequestration and hydrogen production, storage and use;
- Our consultants provide multi-hazard reliability assessment of critical lifelines, such as water and wastewater systems;
- We provide technical consulting services to support governments in the implementation of effective security and defence measures;
- We assist the insurance sector in understanding and mitigating site-specific risk;
- We are members of major industry bodies, including: American Petroleum Institute (API), Carbon Capture & Storage Association (CCSA), Center for Chemical Process Safety (CCPS), Fire and Blast Information Group (FABIG), Mary Kay O'Connor Process Safety Center (MKOPSC), Register of Security Engineers and Specialists (RSES), Society of Petroleum Engineers (SPE), UK Hydrogen and Fuel Cell Association.



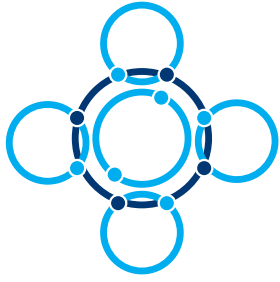

# PFPNet

Hydrocarbon Passive Fire Protection Network

## An Industry Group for Users of PFP in the Hydrocarbon Industries

Passive fire protection (PFP) has been used extensively within the hydrocarbon industry for many decades to mitigate the effects of fire, saving lives and assets. But despite this track record it is often the case that the users of PFP do not fully understand key aspects of this important subject, and the hydrocarbon industries have not always taken on board the lessons learned from the past. This becomes a real problem as more and more manufacturers enter the market with new and improved products, with new features and apparent benefits, whilst many of the original materials are still in service.

MMI Engineering have developed a specialty in consulting related to PFP, and have seen at first hand the results of the misuse and misunderstanding of the systems. To rectify this we have developed an independent, subscription-funded body, dedicated to raising standards in the use of PFP in industries where hydrocarbons are present.

This body is The Hydrocarbon Passive Protection Network – known as **PFPNet**.

Whilst conferences and seminars can inform on what is happening in industry, and manufacturers can provide information on the latest system developments, there is no body which is dedicated to raising standards in the use of PFP by both setting a future technical agenda, and educating based on what has been learned from the past.

PFPNet focuses on serving the needs of the users of hydrocarbon fireproofing materials and systems, through a focus on education, training, capturing and retaining existing knowledge, researching key topics, clarifying points of confusion and disseminating this to the membership - and to the industry at large, with the aim of improving quality.

### What Does PFPNet Cover?

PFPNet covers the following: PFP and CSP coatings; Combined fire and thermal insulation systems on process equipment; Insulated and non-insulated fire and blast barriers (including windows and doors); Penetration seals (including deck penetrations); Jacket and enclosure systems associated with items such as ESDVs; Cable tray fireproofing.

### How Do I Find Out More?

Please contact [info@pfpnet.com](mailto:info@pfpnet.com) for more details and to register your interest in membership. Alternatively, please visit [www.pfpnet.com](http://www.pfpnet.com).

Geosyntec

consultants

[www.geosyntec.com](http://www.geosyntec.com)

[www.geosyntec.eu](http://www.geosyntec.eu)

[www.geosyntec.asia](http://www.geosyntec.asia)

[practices.geosyntec.com/australia-new-zealand](http://practices.geosyntec.com/australia-new-zealand)



engineers • scientists • innovators

[www.mmiengineering.com](http://www.mmiengineering.com)



[www.savronsolutions.com](http://www.savronsolutions.com)



[www.greenharborenergy.com](http://www.greenharborenergy.com)



[www.siremlab.com](http://www.siremlab.com)